



P-ISSN: 2349-8528

E-ISSN: 2321-4902

[www.chemijournal.com](http://www.chemijournal.com)

IJCS 2020; 8(6): 2590-2596

© 2020 IJCS

Received: 18-09-2020

Accepted: 25-10-2020

**Ashaolu Victoria Oladimeji**

Research Scholar, Department of Chemistry, LIFE, Loyola College, Chennai, Tamil Nadu, India

**MF Valan**

Assistant Professor, Department of Chemistry, LIFE, Loyola College, Chennai, Tamil Nadu, India

## HPLC techniques for phytochemistry

**Ashaolu Victoria Oladimeji and MF Valan**

**DOI:** <https://doi.org/10.22271/chemi.2020.v8.i6ak.11174>

### Abstract

There are some drawbacks to existing methods in use for plant content estimation, including large quantities of solvents and long study time. For thousands of years, nature has been a source of therapeutic agents, and an impressive number of modern medicines have been isolated from natural plant sources. Phytochemicals are referred to as the biologically active compounds found in plants. In the cure and treatment of various diseases, these phytochemicals play a major role. It is necessary to have the means available to carry out a characterization of the crude extract to gain access to the therapeutic benefits of these plant species. As a key response to the challenge of detection, characterization and purification of compounds, this paper examines the advances in the high-pressure liquid chromatographic process. This paper focuses on HPLC, an important qualitative and quantitative technique that is commonly used for pharmaceutical and biological sample estimation.

**Keywords:** Phytochemical, qualitative analysis, identification, HPLC

### Introduction

In traditional medicine, plants produce a wide variety of substances that can be used to treat both chronic and infectious diseases (Boligon *et al*, 2012) <sup>[1, 2]</sup>. More than 80 percent of the world's population relies on conventional medicine for their primary healthcare needs, according to the World Health Organization (WHO). Based on tradition, plants have provided a good source of a wide range of compounds such as alkaloids, phenolics, vitamins, terpenes and a number of other secondary metabolites rich in important bioactivities such as antioxidants, antibacterials, anti-cancer, antihepatotoxics, etc. The study of these plant species plays an important role in the discovery and creation of new drugs that in hope, had no side effects but were more successful than current synthetic drugs.

However, in order to validate this conventional assertion, clinical trials are required to show the efficacy of a bioactive compound. Reis, Boligon 2014) <sup>[4]</sup>. Thus the detection, isolation, purification and characterization of phyto-constituents in plants of the active ingredients in the crude sample by means of analytical techniques plays an important role. The choice of plant material is an essential consideration for the overall success of any inquiry into phytochemical plant constituents. Given the large number of plant species that are potentially available for analysis, efficient systems for the rapid chemical and biological screening of plant extracts selected for investigation must be available.

Plant extract contains numerous phyto-compounds of varying degrees of polarity and is still a common problem and key challenge in botanicals and herbal preparations for their extraction, isolation and characterization. By combining basic biological assays with High-Performance Liquid Chromatography (HPLC) analyses, this can be accomplished.

HPLC is an extremely flexible technique; it is the best, most effective, and quickest chromatographic technique for crude plant species quality control. It is an important qualitative and quantitative technique that is commonly used for pharmaceutical and biological sample estimation.

This paper provides descriptions of the extraction, isolation and characterization of bioactive compounds from plant extract with traditional phytochemical screening assays and the use of enhanced HPLC chromatographic techniques.

### Steps to Identification, Characterization and purification of plant extract

#### Extraction

In the study of medicinal plants, extraction is the critical first step, since the desired chemical

**Corresponding Author:****Ashaolu Victoria Oladimeji**

Research Scholar, Department of Chemistry, LIFE, Loyola College, Chennai, Tamil Nadu, India

components need to be extracted from plant materials for further isolation and characterization. Steps such as pre-washing, drying of plant materials or freeze drying, grinding to achieve a homogeneous sample and also improving the kinetics of analytical extraction, as well as increasing the contact of the sample surface with the solvent method were included in the basic operation. Depending on the type of the plant material, various solvent systems are required to extract a bioactive compound from natural products. Maceration, decoction, soxhlet extraction, percolation, infusion, etc., are different extraction methods. (Banu *et al* 2015) <sup>[6]</sup>.

### Phytochemical Screening

Phytochemical screening testing is a simple, easy and inexpensive method that provides A rapid response by the researcher to the different types of phytochemicals in a mixture and an important instrument in bioactive compound analysis.

### Preliminary Qualitative Analysis

#### 1. Test for Alkaloids

##### a. Mayer's test

Add two drops of Mayer's reagent to the sides of the test tube to a few ml of plant sample extract. The presence of alkaloids suggests the emergence of the white creamy precipitate. (Evans WC, 1997) <sup>[7]</sup>

##### b. Wagner's test

A couple of drops of Wagner's reagent are applied to the sides of the test tube to a few ml of plant extract. The test is confirmed as positive by a reddish- brown precipitate. (Wagner H, 1993) <sup>[8]</sup>

#### 2. Test for Amino acids

The extract (100 mg) is dissolved in 10 ml of distilled water and filtered with Whatmann No. 1 philtre paper and subjected to amino acid examination.

##### a. Ninhydrin test

2 ml of aqueous filtrate is added to 2 drops of ninhydrin solution (10 mg of ninhydrin in 200 ml of acetone). The presence of amino acids suggests the existence of a purple hue (Yasuma *et. al*, 1953) <sup>[9]</sup>.

#### 3. Test for Carbohydrates

##### a. Molish' s test

Two drops of alcoholic solution of alpha- naphthol are added to 2 ml of plant sample extract. Shake the mixture well and slowly apply a few drops of concentrated sulphuric acid to the sides of the test tube. The existence of carbohydrates is indicated by a violet ring.

##### b. Benedict' s test

0.5 ml of Benedict` s reagent is added to 0.5 ml of filtrate. The mixture is heated for 2 minutes in a boiling bath of water. The sugar presence is indicated by a typical coloured precipitate.

#### 4. Test for Fixed oils and Fats

##### a. Spot test

Between two filter sheets, a tiny amount of extract is pressed. The presence of fixed oils is indicated by the oil stain on the paper.

##### b. Saponification test

A small amount of extract, along with a drop of

phenolphthalein, is added to a few drops of 0.5 N alcoholic potassium hydroxide solution. The mixture is heated for 2 hours in a water bath. The presence of fixed oils and fats is suggested by soap formation or partial alkali neutralization (Kolkate CK, 1999) <sup>[10]</sup>.

### 5. Test for Glycosides

For 50 mg of extract, concentrated hydrochloric acid is hydrolysed, purified and the hydrolysate is subjected to the following tests for 2 hours in a water bath.

#### a. Borntrager's test

3 ml of chloroform is added to 2 ml of filtered hydrolysate and shaken, the chloroform layer is removed and 10 percent ammonia solution is added to it. The presence of glycosides suggests a pink hue. (Evans WC, 1997) <sup>[7]</sup>.

#### b. Legal's test

In pyridine, 50 mg of extract is dissolved, sodium nitroprusside solution is added and alkaline is produced using 10 percent Na OH. The pink colour shows the presence of glycoside.

### 6. Test for Phenolic compounds and Tannins

#### a. Ferric Chloride test

In 5 ml of distilled water, the extract (50 mg) is dissolved. A neutral 5 percent ferric chloride solution is applied to these few drops. The presence of phenolic compounds is indicated by a dark green hue (Mace. M.D, 1963) <sup>[11]</sup>.

#### b. Gelatin test

The extract (50 mg) is dissolved in 5 ml of distilled water and is added to 2 ml of 1% Gelatin solution containing 10% NaCl. The presence of phenolic compounds is indicated by White Precipitate (Evans WC, 1997) <sup>[7]</sup>

#### c. Lead acetate test

The extract (50 mg) is dissolved in sterile water and a 10 percent lead acetate solution is added to this 3 ml solution. The presence of phenolic compounds suggests a bulky white precipitate.

#### d. Alkaline reagent test

A 10 percent solution of ammonium hydroxide is treated with an aqueous solution of the extract. Yellow fluorescence suggests that flavonoids are present.

#### e. Magnesium and Hydrochloric acid reduction

The extract (50 mg) is dissolved in 5 ml of alcohol and only a few fragments of magnesium ribbon and hydrochloric acid concentrate (drop wise) are added. If any pink to crimson color occurs, flavonol glucosides are inferred from the presence of flavanol glucosides is inferred. (Harborne. J.B 1998) <sup>[12]</sup>.

### 7. Test for phytosterols

#### a. Libermann-Burchard's test

The extract (50 mg) is dissolved in a 2 ml acetic anhydride formulation. To do this, slowly apply 1 or 2 drops of concentrated sulphuric acid along the sides of the test tube. The presence of phytosterols is shown by a colour shift array. (Finar I.L 1986) <sup>[13]</sup>.

### 8. Test for Proteins

The extract (100 mg) is dissolved in 10 ml of distilled water and filtered through the philtre paper of Whatmann No. 1 and the filtrate is screened for protein.

**a. Millon's test**

A few drops of Millon's reagent are applied to 2 ml of filtrate. A white precipitate suggests that protein is present. (Rasch. E. *et al.*, 1960) <sup>[14]</sup>.

**b. Biuret test**

With 1 drop of 2 percent copper sulphate solution, 2 ml of filtrate is treated. 1 ml of ethanol (95 per cent) is added to this, followed by excess pellets of potassium hydroxide. The presence of protein is suggested by the pink ethanolic layer (Gahan. P.B, 1984) <sup>[15]</sup>.

**9. Test for Saponins**

The extract (50 mg) is diluted with distilled water and up to 20 ml is formed. In a graduated cylinder, the suspension will shake for 15 minutes. The existence of saponins is indicated by a two-cm layer of foam. (Kolkate CK, 1999) <sup>[10]</sup>.

**10. Test for gum and Mucilages**

The extract (100 mg) is dissolved in 10 ml of distilled water and with continuous stirring, 2 ml of absolute alcohol is added to it. The presence of gums and mucilages is suggested by a white or cloudy precipitate (Whistler.R.L *et al.* 1993) <sup>[16]</sup>.

**11. Test for volatile oil**

50 mg of powdered material (crude drug) is taken and subjected to hydro-distillation for volatile oil estimation. The distillate is collected in the assembly's graduate tube, where the aqueous component is immediately isolated from the volatile oil. (James.E *et al* 1996) <sup>[17]</sup>

**Identification and Characterization**

Since plant extracts normally occur as a mixture of various

phyto-compounds or phytochemicals with various polarities, their separation remains a major challenge for the compound identification and characterization process. Panel chromatography, Flash Chromatography, etc., among other techniques such as TLC, In order to obtain pure compounds, HPLC has proven to be the most powerful and safest analytical method that is necessary for isolation. The pure compounds are then used for structure and biological activities to be determined. Option for a fingerprinting study for herbal plant quality control (Fan *et al.*, 2006) <sup>[18]</sup>. Crude plant material extract is first isolated to achieve optimum phyto-compound characterization.

High-pressure liquid chromatographic (HPLC) methods previously reported have some disadvantages that require a long period of study, but their development has made this technique more economical and appropriate for large batches of samples. A solvent delivery pump, a sample introduction system such as an auto-sampler or manual injection valve, an analytical column, a guard column, a detector and a recorder or a printer are now modular in nature and constitute an HPLC instrument.

**Working Principle of An HPLC**

The liquid phase is pumped onto the column packed with the stationary phase at a constant rate. The analysis sample is injected into the carrier stream before entering the column. The sample components are selectively retained upon reaching the column on the basis of physico-chemical interactions between the molecules of the analyte and the stationary step. Based on the operating conditions, the mobile process that moves at a steady pace elutes the components. Techniques of detection are used to detect and measure the eluted components.

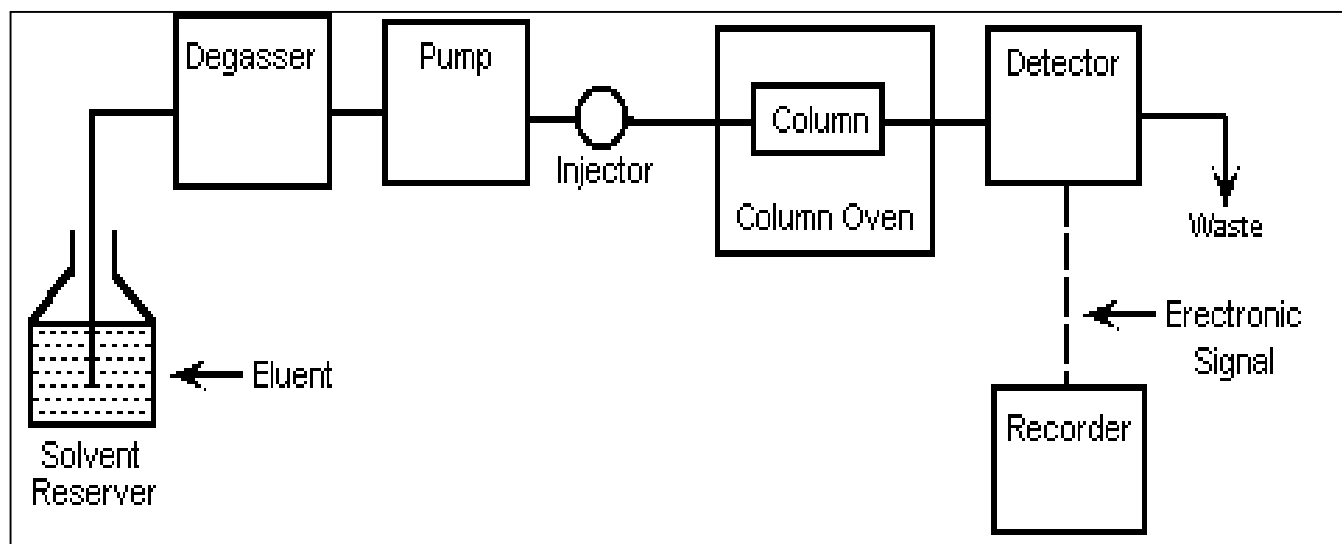

**Fig 1:** Schematic lay-out of a HPLC System

**Table 1:** Show the system component description

System Component	Description
Mobile Phase Reservoir	Stores the mobile phase required for analysis
Degasser	Degasses the mobile phase
Pump	Solvent delivery system, enables the flow of mobile phase through the system
Injector	Sample delivery system, introduces the sample to the system
Column compartment	Used to control the temperature of column
Detector	Detects each component in a separated mixture after elution from column
Data processor (Recorder)	Convert data from detector into meaningful information
Waste	Collection of the liquid waste or impurities.

### High Performance Liquid Chromatography

HPLC is also known as Liquid Chromatography with High-Pressure. Based on their contact with solid particles of a tightly packed column and the solvent of the mobile phase, this distinguishes compounds. High-performance liquid chromatography (HPLC) is a flexible, stable, and commonly used process for natural product isolation (Cannell, 1998) <sup>[20]</sup>. This technique is currently gaining popularity among different analytical techniques. It is particularly suitable for compounds

whose molecular weights are not easily volatilized, thermally unstable and strong.

The HPLC analytical method used for the detection, chemical separation, purification, quantification of drugs either in their active pharmaceutical ingredient or in their formulations during the three main phases of drug discovery, drug production and manufacturing is the most characteristic feature of the development in the methodological analysis of drugs. (Basal *et al.* 2010) <sup>[21]</sup>.

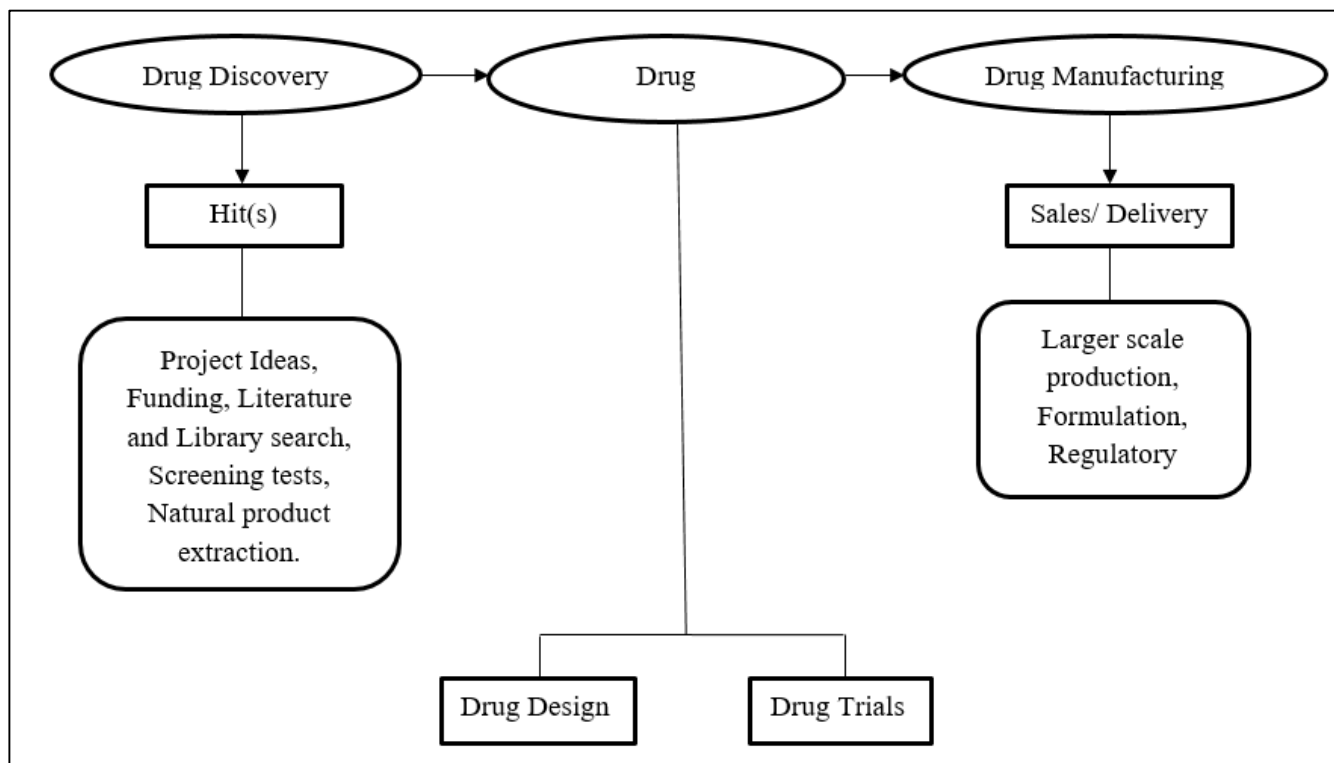

**Fig 2:** The various stages in new drug developmental analysis

### Characteristics of HPLC Technique

Using HPLC, chemical separations can be achieved by using the fact that, depending on polarities given a specific column and mobile phase, some compounds have different migration rates. The separation rate is calculated mainly by the option of the stationary phase and the mobile phase.

The method of separating or removing the target compound from other (possibly structurally related compounds or contaminants) is the purification of the crude extract of interest using HPLC. Under certain chromatographic conditions, each compound should have a characteristic peak. Sasidharan *et al.*, (2011) <sup>[19]</sup>

A key aspect of any HPLC assay is the detection of phytochemical compounds by HPLC. A detector has to be selected first to classify any compound by HPLC. A separation assay must be established once the detector has been selected and is set to optimum detection settings. The parameters of this assay should be such that a clean peak from the chromatograph is observed from the known sample. The identifying peak should have a fair retention time and at the

detection levels that the assay would be conducted should be well differentiated from extraneous peaks. Of all detectors, UV detectors are popular because they give high sensitivity and also because most naturally occurring compounds have some UV absorption at low wavelengths (190-210 nm) (Cannell, 1998) <sup>[20]</sup>.

### Types OF HPLC

The types of HPLC are dependent on phase system used in the process. (Abidi, S.L, 1991 Hearn M.T.W, 1980) <sup>[22, 23]</sup>. HPLC are generally categorized into the following: -

#### Normal phase chromatography

This process is also known as Normal Phase HPLC (NP-HPLC), which distinguishes polarity-based phyto-compounds. NP-HPLC deals with the polar stationary phase and the non-polar mobile phase concept. Interaction takes place in stages, and in the polar stationary phase, polar phyto-compounds appear to be retained.

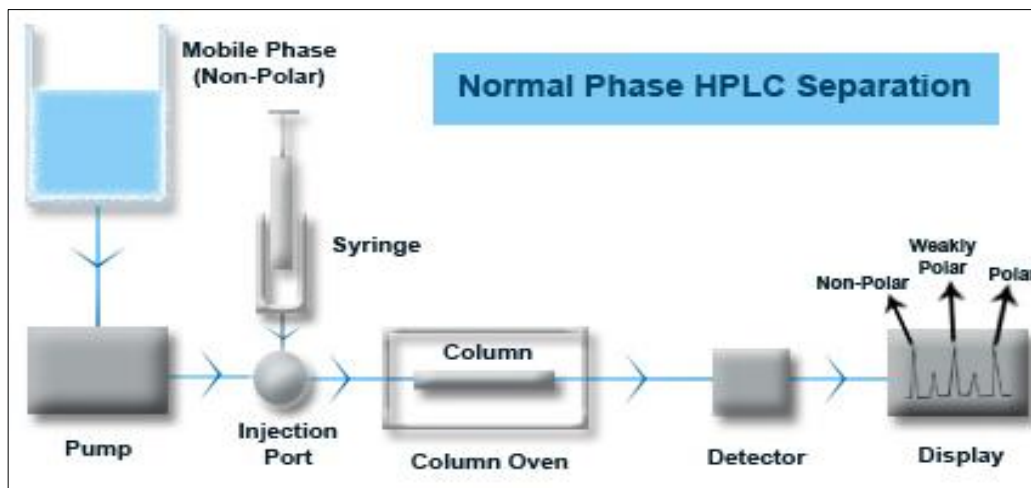

Fig 3: Show the normal phase HPLC separation

With increased compound polarity, adsorption strengths increase, and the interaction between the polar compound and the polar stationary phase increases the elution time. The order of elution is non-polar molecules, followed in the end by weakly polar and polar molecules.

### Reversed phase chromatography

The reverse phase HPLC (RPC) is the opposite of the standard phase, which acts on the hydrophobic interactions

principle arising from the repulsive forces between the polar eluent, the comparatively non-polar analyte, and the stationary phase of the non-polar phase. RPC has an aqueous, moderately polar mobile phase and a non-polar stationary phase, and the order of elution is polar, followed to the end by less polar and weakly polar or non-polar compounds. The improved developmental version of the HPLC system is reversed-phase chromatography, mainly used for phyto-compound separation due to its large range of applications.

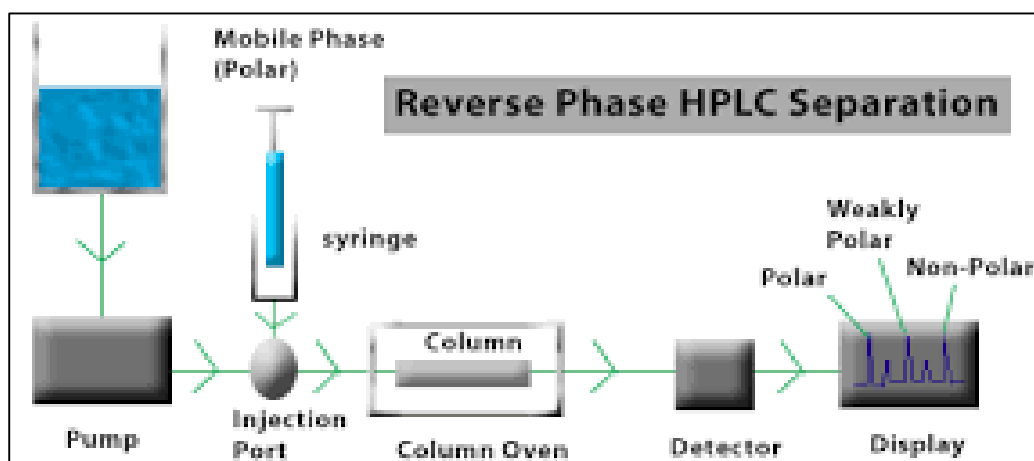

Fig 4: The reverse phase HPLC separation

Over 65 percent of all HPLC separations are estimated to be carried out in the reversed phase mode. The reasons for this are the flexibility, versatility and scope of the reverse phase process, as it has a great advantage in analysing compounds of varying polarity and molecular mass compared to normal phase chromatography (Ahuja S,2006. Prathap B *et al*, 2013) [24, 25].

### Ion exchange chromatography

Retention is based on the attractive forces between solvent ions and charged sites bound to the stationary phase, the theory of ion-exchange chromatography. Ions are exempt from the same fee. This method of chromatography is commonly used in water purification, Ligand-exchange chromatography, protein Ion-exchange chromatography, carbohydrate and oligosaccharide High-pH anion-exchange chromatography, etc. Component separation can be controlled by control of mobile phase pH, temperature, ionic composition and modifier addition.

### Size Exclusion Chromatography

On the basis of the molecular size of molecules, separation occurs. In the stationary phase pores, small molecules get stuck and escape after the big molecules. In the phase of separation, there are no chemical or ionic forces involved. For the isolation of large molecules, such as polysaccharides, peptides, proteins and polymers, this approach is used.

### Factors Affecting the Sensitivity of HPLC Technique Particle Size

The smaller particle size contributes to an increased surface area that is required for better separation.

### Pore Size

Pore size is the capacity of the molecule of the analyte to penetrate the particles and interact with the inner surface. Porous stationary phases maximise the surface area, contributing to enhanced kinetics.

**Internal Diameter**

This defines the sample quantity that can be loaded into the column. It affects sensitivity if technique is involved.

**Pump Pressure**

In terms of pressure capacity, the sensitivity of the HPLC method varies. Performance, however is measured based on consistency and the reproducible flow rate factor.

**Applications of HPLC**

In various fields, such as pharmaceuticals, foods, life sciences, climate, forensics, etc, HPLC has contributed to phytochemical analytical solutions. I will speak about a couple of its areas of use in pharmaceuticals and foods.

**Pharmaceutical Applications of HPLC**

High Performance Liquid Chromatography, along with a high linear dynamic range, provides accurate quantitative precision and accuracy to allow the determination of APIs and related substances in a single run. Dispersion in water or aqueous media modified with acetonitrile or methanol is a convenient procedure for sample preparation for solid dosage types. HPLC provides many possibilities for chiral molecules to be isolated into their respective enantiomers. In short, the most common option for quantitative analysis in the pharmaceutical industry is HPLC, especially reverse phase HPLC.

Common application areas in pharmaceutical analysis are:

- Assay
- Related Substances
- Analytical method validation
- Stability Studies
- Compounds Identification
- Working Standards

**Application of HPLC In Food Analysis**

In the field of food analysis, High Performance Liquid Chromatography has brought desirable benefits. In general food matrices are complex, and analyte extraction is not a simple task. Both desirable and undesirable components are often found in trace levels and classical extraction to further complicate matters, and analysis does not provide the required levels of accuracy and precision. Due to the broad choice of stationary phases and mobile phase options, HPLC provides viable solutions.

**Common applications in foods are**

- Fat soluble vitamins (A, D, E and K)
- Water soluble vitamins (B-complex vitamins such as B1, B2, B6, B12, Vitamin C)
- Residual pesticides such as 2, 4-D and Monochrotophos
- Antioxidants such as TBHQ, BHA, and BHT
- Sugars: Glucose, Fructose, Maltose and other saccharides
- Cholesterol and sterols
- Dyes and synthetic colors
- Mycotoxins such as Aflatoxins B1, B2, G1, G2, and Ochratoxins
- Amino acids
- Residual antibiotics
- Steroids and Flavonoids
- Aspartame and other artificial sweeteners
- Active ingredients of farm produce such as allin in garlic and catechin in tea extracts.

**Conclusion**

This review provided an overview of the improved HPLC technique known as Quick ANALYSIS, used for the analysis of plant-based phytochemical compounds. The advantages of this approach are various. HPLC requires less time, in addition to its reproducibility and protection, and small solvent volumes are sufficient to produce sensitivity without loss of recovery. In areas such as pharmaceuticals, life sciences, foods, polymers and forensics, the growth of HPLC has been phenomenal. HPLC has resulted in enhanced isolation, recognition, purification and quantification of complex bio-active compound molecules over previously proven techniques useful for detection, leading to the discovery and development of drugs. In addition, to perform more than a single-run analysis required for the qualitative and quantitative estimation and separation of pharmacologically active phyto-compounds isolated for the cure and treatment of human diseases, the HPLC technique can be upgraded. This activity remains evolutionary and in its field of instrumentation requires technical development.

**References**

1. Boligon AA, Agertt V, Janovik V, Cruz RC, Campos MMA, Guillaume D *et al.* Antimycobacterial activity of the fractions and compounds from *Scutia buxifolia*. *Revista Brasileira de Farmacognosia* 2012;22:45-52.
2. Boligon AA, Janovik V, Frohlich JK, Spader TB, Froeder AL, Alves S *et al.* Antimicrobial and cytotoxic activities of leaves, twigs and stem bark of *Scutia buxifolia* Reissek. *Nat Prod Res* 2012;26:939-944.
3. Reis Ede M, Schreiner Neto FW, Cattani VB, Peroza LR, Busanello A, Leal CQ *et al.* Antidepressant-like effect of *Ilex paraguariensis* in rats. *Biomed Res Int* 2014, 2014: 958209.
4. Boligon AA, Machado MM, Athayde ML. Technical Evaluation of Antioxidant Activity. *Med chem* 2014;4:517-522.
5. Aline Augusti Boligon, Margareth Linde Athayde. Importance of HPLC in Analysis of Plants Extracts. Austin Publishing group 2014.
6. Sahira Banu K, Dr. Cathrine General L. Techniques Involved in Phytochemical Analysis *International Journal of Advanced Research in Chemical Science (IJARCS)* 2015;2(4):25-32
7. Evans WC. *Trease and Evans Pharmacognosy*, Harcourt Brace and company. Asia pvt. Ltd. Singapore 1997.
8. Wagner H. *Pharmazeutische Biologie*, 5 th Edition, AUFI.15 BN 3-437-20 498-X, 1993.
9. Yasuma A, Ichikawa. "Ninhydrin-Schiff and alloxan-Schiff staining. A new gIn histochemical staining methods for proteins", *J. Lab clin Med* 1953;41:296-299.
10. Kokate CK. *Practical pharmacognosy* 4 th edition, Vallabh Prakashan Publication, New Delhi, India 1999.
11. Mace MD. "Histochemical localization of phenols in healthy and diseased tomato roots, *Phytopathology* 1963;16:915-925.
12. Harborne JB. "Phytochemical Methods: A Guide To Modern Techniques of Plant Analysis." 2nd Edition, Chapman and Hall Publishers, London, 1998.
13. Finar IL. *Stereo Chemistry and the Chemistry of Natural Products* Longman 1986, 2
14. Rasch E, Swift H. Micro Photometric Analysis of the Cytochemical millon reaction, *J. Histochem. Cytochem.* 1960;8:4-17.

15. Gahan PB. Plant Histochemistry and Cytochemistry: An Introduction. Academic Press, Florida, U.S.A 1984.
16. Whistler RL, BeMiller JN. Industrial Gums; Polysaccharides and their Derivatives, Academic Press, London 1993.
17. James EK, Robbers M Speedie, Varro Tyler E. Pharmacognosy and pharmaco Biotechnology, Williams and Willkins, New York, U.S.A 1996.
18. Fan XH, Cheng YY, Ye ZL, Lin RC, Qian ZZ. Multiple chromatographic fingerprinting and 18. its application to the quality control of herbal medicines. Anal Chim Acta. 2006;555:217-224.
19. Sasidharan. Extraction, Isolation And Characterization Of Bioactive Compounds From Plants' Extracts Afr J Tradit Complement Altern Med 2011;8(1):1-10.
20. Cannell RJP. Natural Products Isolation. Human Press Inc. New Jersey 1998,165-208.
21. Bansal V. *et al* High Performance Liquid Chromatography: A Short Review Journal Of Global Pharma Technology 2010;2(5):22-26
22. Abidi SL. High-performance liquid chromatography of phosphatidic acids and related polar lipids. J. Chromatogr 1991;587:193-203.
23. Hearn MTW. Ion-pair chromatography on normal and reversed-phase systems. Adv. Chromatogr 1980;18:59-100.
24. Ahuja S, Ahuja S. High Pressure Liquid Chromatography. Comprehensive Analytical Chemistry. Elsevier 2006.
25. Prathap B, Dey A, Srinivasarao GH, Johnson P, Arthanariswaran P. A Review - importance of RP-HPLC in analytical method development. International Journal of Novel Trends in Pharmaceutical Sciences 2013;3:15-23.